

**OFFICE USE ONLY**

Date Recd: \_\_\_\_\_

Staff Initials: \_\_\_\_\_

Deposit Amount: \_\_\_\_\_

**DOCK SLIP MOVE LIST POLICY**

If a member claims a slip and would like to stay on the list, they may do so, but will be transferred to the "Move List". Members on this list will provide at minimum, (3) slip location preferences. Should a slip within that preference selection become available, Members on the Move List will be contacted first. Staff will then continue down the waiting list to fill the vacancies from these changes.

Complete the section below if you would like to be added to the Move List. Please provide **a minimum** of (3) slip locations.

Slip Location Preferences			
Slip Type <i>(please circle one)</i>	Electric		Non-Electric
Slip # <i>(in order of priority)</i>			

Name: \_\_\_\_\_ Tract – lot: \_\_\_\_\_

Address: \_\_\_\_\_

Member Signature: \_\_\_\_\_ Date: \_\_\_\_\_

# CANYON LAKE RENTAL DOCKS

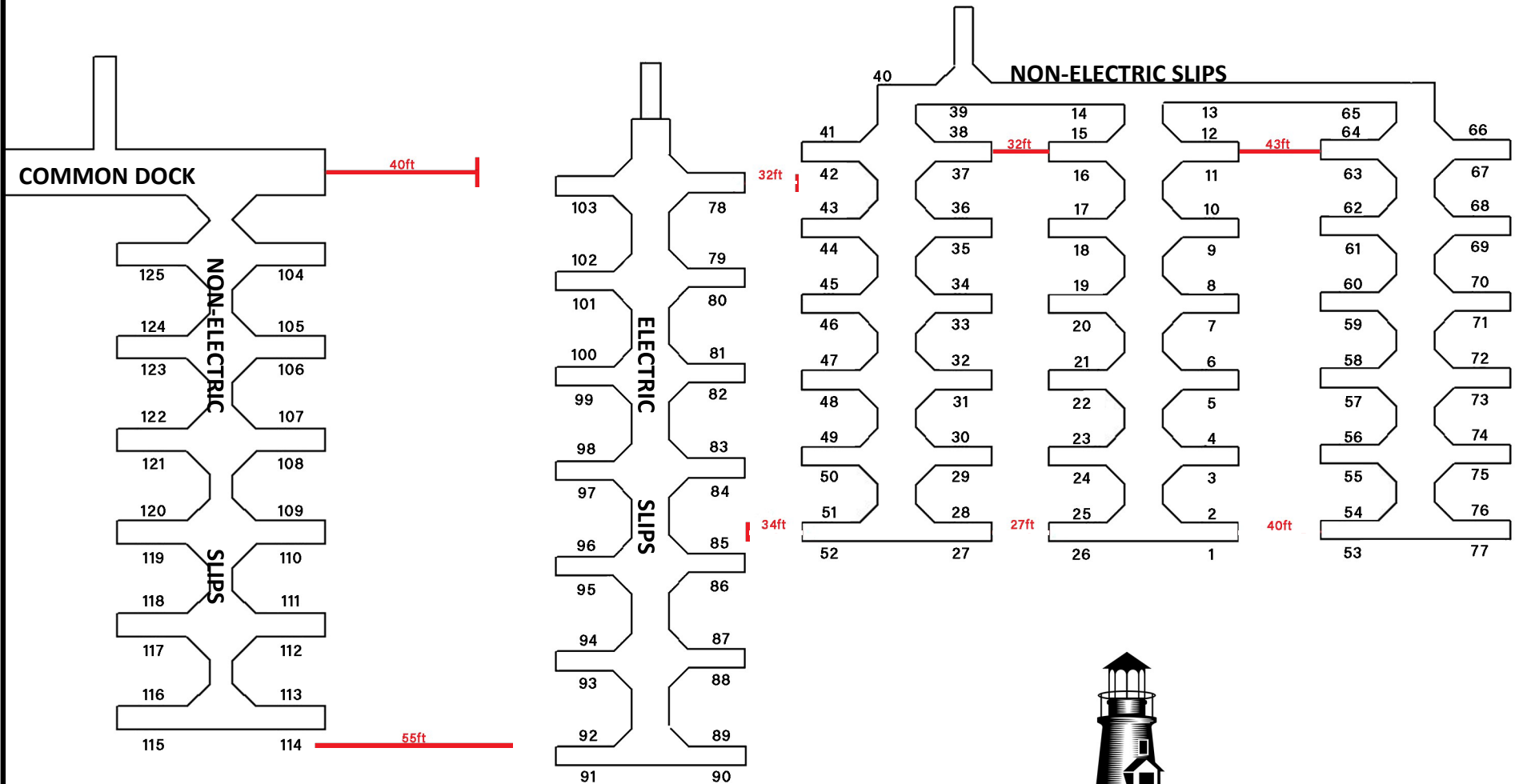

CANYON LAKE

PROPERTY OWNERS ASSOCIATION

\*NOT TO SCALE